

CHAPTER 2

BATTERIES

LEARNING OBJECTIVES

Upon completing this chapter, you will be able to:

1. State the purpose of a cell.
2. State the purpose of the three parts of a cell.
3. State the difference between the two types of cells.
4. Explain the chemical process that takes place in the primary and secondary cells.
5. Recognize and define the terms electrochemical action, anode, cathode, and electrolyte.
6. State the causes of polarization and local action and describe methods of preventing these effects.
7. Identify the parts of a dry cell.
8. Identify the various dry cells in use today and some of their capabilities and limitations.
9. Identify the four basic secondary cells, their construction, capabilities, and limitations.
10. Define a battery, and identify the three ways of combining cells to form a battery.
11. Describe general maintenance procedures for batteries including the use of the hydrometer, battery capacity, and rating and battery charging.
12. Identify the five types of battery charges.
13. Observe the safety precautions for working with and around batteries.

INTRODUCTION

The purpose of this chapter is to introduce and explain the basic theory and characteristics of batteries. The batteries which are discussed and illustrated have been selected as representative of many models and types which are used in the Navy today. No attempt has been made to cover every type of battery in use, however, after completing this chapter you will have a good working knowledge of the batteries which are in general use.

First, you will learn about the building block of all batteries, the CELL. The explanation will explore the physical makeup of the cell and the methods used to combine cells to provide useful voltage, current, and power. The chemistry of the cell and how chemical action is used to convert chemical energy to electrical energy are also discussed.

In addition, the care, maintenance, and operation of batteries, as well as some of the safety precautions that should be followed while working with and around batteries are discussed.

Batteries are widely used as sources of direct-current electrical energy in automobiles, boats, aircraft, ships, portable electric/electronic equipment, and lighting equipment. In some instances, they are used as the only source of power; while in others, they are used as a secondary or standby power source.

A battery consists of a number of cells assembled in a common container and connected together to function as a source of electrical power.

THE CELL

A cell is a device that transforms chemical energy into electrical energy. The simplest cell, known as either a galvanic or voltaic cell, is shown in figure 2-1. It consists of a piece of carbon (C) and a piece of zinc (Zn) suspended in a jar that contains a solution of water (H_2O) and sulfuric acid (H_2SO_4) called the electrolyte.

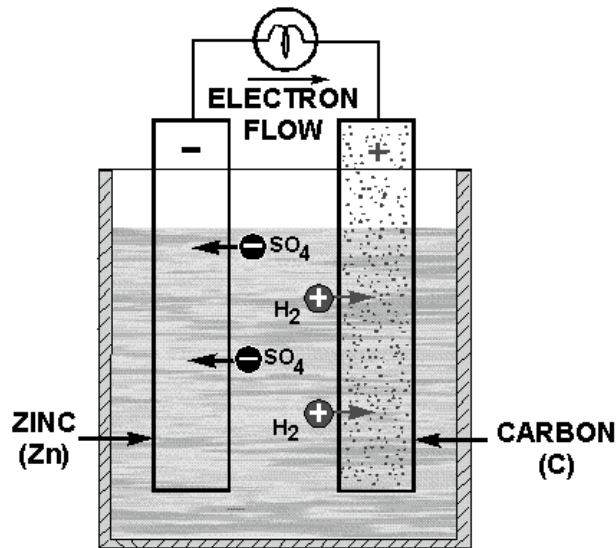

Figure 2-1.—Simple voltaic or galvanic cell.

The cell is the fundamental unit of the battery. A simple cell consists of two electrodes placed in a container that holds the electrolyte.

In some cells the container acts as one of the electrodes and, in this case, is acted upon by the electrolyte. This will be covered in more detail later.

ELECTRODES

The electrodes are the conductors by which the current leaves or returns to the electrolyte. In the simple cell, they are carbon and zinc strips that are placed in the electrolyte; while in the dry cell (fig. 2-2), they are the carbon rod in the center and zinc container in which the cell is assembled.

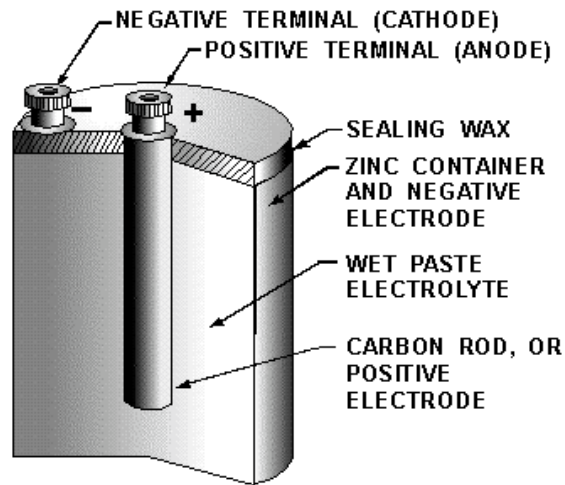

Figure 2-2.—Dry cell, cross-sectional view.

ELECTROLYTE

The electrolyte is the solution that acts upon the electrodes. The electrolyte, which provides a path for electron flow, may be a salt, an acid, or an alkaline solution. In the simple galvanic cell, the electrolyte is in a liquid form. In the dry cell, the electrolyte is a paste.

CONTAINER

The container which may be constructed of one of many different materials provides a means of holding (containing) the electrolyte. The container is also used to mount the electrodes. In the voltaic cell the container must be constructed of a material that will not be acted upon by the electrolyte.

- Q1. What is the purpose of a cell?*
- Q2. What are the three parts of a cell?*
- Q3. What is the purpose of each of the three parts of a cell?*

PRIMARY CELL

A primary cell is one in which the chemical action eats away one of the electrodes, usually the negative electrode. When this happens, the electrode must be replaced or the cell must be discarded. In the galvanic-type cell, the zinc electrode and the liquid electrolyte are usually replaced when this happens. In the case of the dry cell, it is usually cheaper to buy a new cell.

SECONDARY CELL

A secondary cell is one in which the electrodes and the electrolyte are altered by the chemical action that takes place when the cell delivers current. These cells may be restored to their original condition by forcing an electric current through them in the direction opposite to that of discharge. The automobile storage battery is a common example of the secondary cell.

Q4. *What are the two types of cells?*

Q5. *What is the main difference between the two types of cells?*

ELECTROCHEMICAL ACTION

If a load (a device that consumes electrical power) is connected externally to the electrodes of a cell, electrons will flow under the influence of a difference in potential across the electrodes from the CATHODE (negative electrode), through the external conductor to the ANODE (positive electrode).

A cell is a device in which chemical energy is converted to electrical energy. This process is called ELECTROCHEMICAL action.

The voltage across the electrodes depends upon the materials from which the electrodes are made and the composition of the electrolyte. The current that a cell delivers depends upon the resistance of the entire circuit, including that of the cell itself. The internal resistance of the cell depends upon the size of the electrodes, the distance between them in the electrolyte, and the resistance of the electrolyte. The larger the electrodes and the closer together they are in the electrolyte (without touching), the lower the internal resistance of the cell and the more current the cell is capable of supplying to the load.

Q6. *What is electrochemical action?*

Q7. *What is another name for the (a) positive electrode, and the (b) negative electrode?*

PRIMARY CELL CHEMISTRY

When a current flows through a primary cell having carbon and zinc electrodes and a diluted solution of sulfuric acid and water (combined to form the electrolyte), the following chemical reaction takes place.

The current flow through the load is the movement of electrons from the negative electrode of the cell (zinc) and to the positive electrode (carbon). This causes fewer electrons in the zinc and an excess of electrons in the carbon. Figure 2-1 shows the hydrogen ions (H_2) from the sulfuric acid being attracted to the carbon electrode. Since the hydrogen ions are positively charged, they are attracted to the negative charge on the carbon electrode. This negative charge is caused by the excess of electrons. The zinc electrode has a positive charge because it has lost electrons to the carbon electrode. This positive charge attracts the negative ions (SO_4) from the sulfuric acid. The negative ions combine with the zinc to form zinc sulfate. This action causes the zinc electrode to be eaten away. Zinc sulfate is a grayish-white substance that is sometimes seen on the battery post of an automobile battery.

The process of the zinc being eaten away and the sulfuric acid changing to hydrogen and zinc sulfate is the cause of the cell discharging. When the zinc is used up, the voltage of the cell is reduced to zero.

In figure 2-1 you will notice that the zinc electrode is labeled negative and the carbon electrode is labeled positive. This represents the current flow outside the cell from negative to positive.

The zinc combines with the sulfuric acid to form zinc sulfate and hydrogen. The zinc sulfate dissolves in the electrolyte (sulfuric acid and water) and the hydrogen appears as gas bubbles around the carbon electrode. As current continues to flow, the zinc gradually dissolves and the solution changes to zinc sulfate and water. The carbon electrode does not enter into the chemical changes taking place, but simply provides a return path for the current.

Q8. In the primary cell, why are negative ions attracted to the negative terminal of the cell?

Q9. How do electrons get from the negative electrode to the positive electrode?

Q10. What causes the negative electrode to be eaten away?

SECONDARY CELL CHEMISTRY

As stated before, the differences between primary and secondary cells are, the secondary cell can be recharged and the electrodes are made of different materials. The secondary cell shown in figure 2-3 uses sponge lead as the cathode and lead peroxide as the anode. This is the lead-acid type cell and will be used to explain the general chemistry of the secondary cell. Later in the chapter when other types of secondary cells are discussed, you will see that the materials which make up the parts of a cell are different, but that the chemical action is essentially the same.

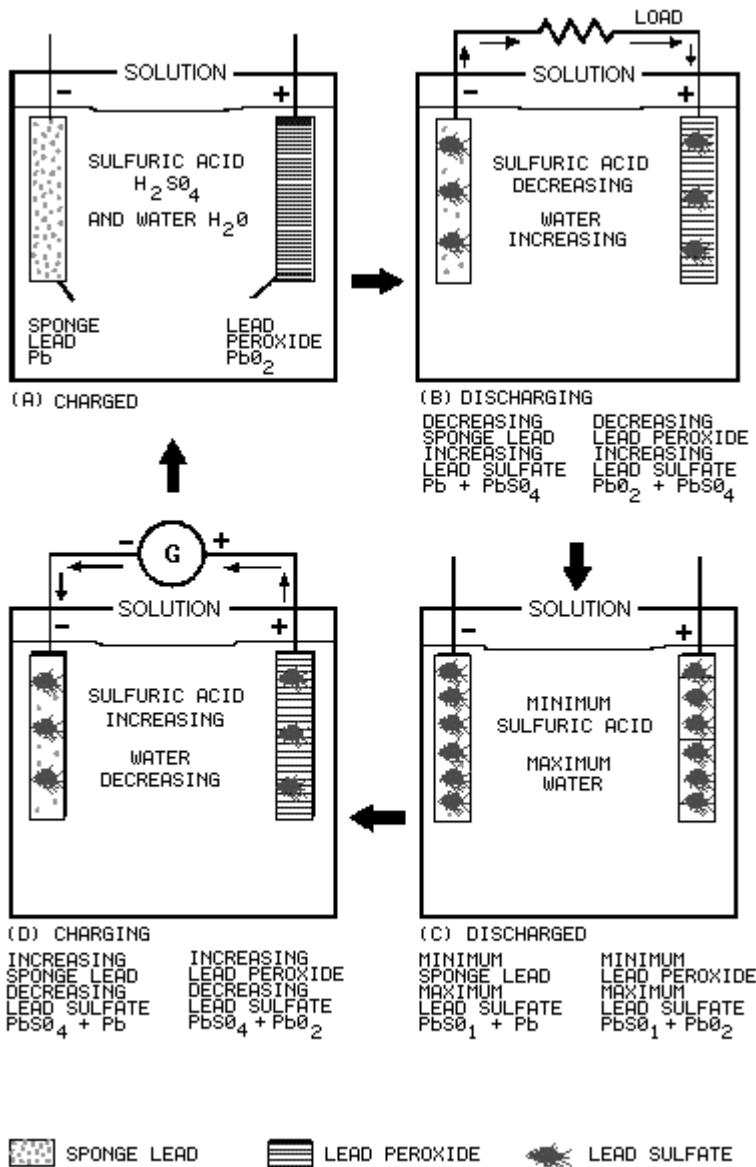

Figure 2-3.—Secondary cell.

Figure 2-3 view A shows a lead-acid secondary cell that is fully charged. The cathode is pure sponge lead, the anode is pure lead peroxide, and the electrolyte is a mixture of sulfuric acid and water.

Figure 2-3 view B shows the secondary cell discharging. A load is connected between the cathode and anode; current flows negative to positive as shown. This current flow creates the same process as was explained for the primary cell with the following exceptions.

In the primary cell the zinc cathode was eaten away by the sulfuric acid. In the secondary cell the sponge-like construction of the cathode retains the lead sulfate formed by the chemical action of the sulfuric acid and the lead. In the primary cell the carbon anode was not chemically acted upon by the sulfuric acid. In the secondary cell the lead peroxide anode is chemically changed to lead sulfate by the sulfuric acid.

When the cell is fully discharged it will be as shown in figure 2-3 view C. The anode and cathode retain some lead peroxide and sponge lead but the amounts of lead sulfate in each is maximum. The electrolyte has a minimum amount of sulfuric acid. With this condition no further chemical action can take place within the cell.

As you know, the secondary cell can be recharged. Recharging is the process of reversing the chemical action that occurs as the cell discharges. To recharge the cell, a voltage source, such as a generator, is connected as shown in figure 2-3 view D. The negative terminal of the voltage source is connected to the cathode of the cell and the positive terminal of the voltage source is connected to the anode of the cell. With this arrangement the lead sulfate is chemically changed back to sponge lead in the cathode, lead peroxide in the anode, and sulfuric acid in the electrolyte. After all the lead sulfate is chemically changed, the cell is fully charged as shown in figure 2-3 view A. Once the cell has been charged, the discharge-charge cycle may be repeated.

Q11. Refer to figure 2-3(B). Why is the sulfuric acid decreasing?

Q12. Refer to figure 2-3(D). How is it possible for the sulfuric acid to be increasing?

Q13. Refer to figure 2-3(D). When all the lead sulfate has been converted, what is the condition of the cell?

POLARIZATION OF THE CELL

The chemical action that occurs in the cell while the current is flowing causes hydrogen bubbles to form on the surface of the anode. This action is called POLARIZATION. Some hydrogen bubbles rise to the surface of the electrolyte and escape into the air, some remain on the surface of the anode. If enough bubbles remain around the anode, the bubbles form a barrier that increases internal resistance. When the internal resistance of the cell increases, the output current is decreased and the voltage of the cell also decreases.

A cell that is heavily polarized has no useful output. There are several methods to prevent polarization or to depolarize the cell.

One method uses a vent on the cell to permit the hydrogen to escape into the air. A disadvantage of this method is that hydrogen is not available to reform into the electrolyte during recharging. This problem is solved by adding water to the electrolyte, such as in an automobile battery. A second method is to use material that is rich in oxygen, such as manganese dioxide, which supplies free oxygen to combine with the hydrogen and form water.

A third method is to use a material that will absorb the hydrogen, such as calcium. The calcium releases hydrogen during the charging process. All three methods remove enough hydrogen so that the cell is practically free from polarization.

LOCAL ACTION

When the external circuit is removed, the current ceases to flow, and, theoretically, all chemical action within the cell stops. However, commercial zinc contains many impurities, such as iron, carbon, lead, and arsenic. These impurities form many small electrical cells within the zinc electrode in which current flows between the zinc and its impurities. Thus, the chemical action continues even though the cell itself is not connected to a load.

Local action may be prevented by using pure zinc (which is not practical), by coating the zinc with mercury, or by adding a small percentage of mercury to the zinc during the manufacturing process. The treatment of the zinc with mercury is called amalgamating (mixing) the zinc. Since mercury is many times heavier than an equal volume of water, small particles of impurities weighing less than mercury will float to the surface of the mercury. The removal of these impurities from the zinc prevents local action. The mercury is not readily acted upon by the acid. When the cell is delivering current to a load, the mercury continues to act on the impurities in the zinc. This causes the impurities to leave the surface of the zinc electrode and float to the surface of the mercury. This process greatly increases the storage life of the cell.

Q14. Describe three ways to prevent polarization.

Q15. Describe local action

TYPES OF CELLS

The development of new and different types of cells in the past decade has been so rapid that it is virtually impossible to have a complete knowledge of all the various types. A few recent developments are the silver-zinc, nickel-zinc, nickel-cadmium, silver-cadmium, organic and inorganic lithium, and mercury cells.

PRIMARY DRY CELL

The dry cell is the most popular type of primary cell. It is ideal for simple applications where an inexpensive and noncritical source of electricity is all that is needed.

The dry cell is not actually dry. The electrolyte is not in a liquid state, but is a moist paste. If it should become totally dry, it would no longer be able to transform chemical energy to electrical energy.

Construction of a Dry Cell

The construction of a common type of dry cell is shown in figure 2-4. These dry cells are also referred to as Leclanche' cells. The internal parts of the cell are located in a cylindrical zinc container. This zinc container serves as the negative electrode (cathode) of the cell. The container is lined with a nonconducting material, such as blotting paper, to separate the zinc from the paste. A carbon electrode is located in the center, and it serves as the positive terminal (anode) of the cell. The paste is a mixture of several substances such as ammonium chloride, powdered coke, ground carbon, manganese dioxide, zinc chloride, graphite, and water.

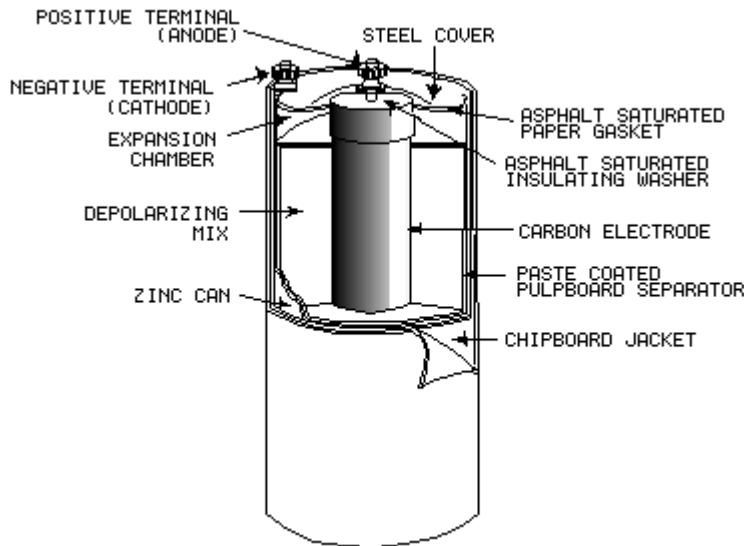

Figure 2-4.—Cutaway view of the general-purpose dry cell.

This paste, which is packed in the space between the anode and the blotting paper, also serves to hold the anode rigid in the center of the cell. When the paste is packed in the cell, a small space is left at the top for expansion of the electrolytic paste caused by the depolarization action. The cell is then sealed with a cardboard or plastic seal.

Since the zinc container is the cathode, it must be protected with some insulating material to be electrically isolated. Therefore, it is common practice for the manufacturer to enclose the cells in cardboard and metal containers.

The dry cell (fig. 2-4) is basically the same as the simple voltaic cell (wet cell) described earlier, as far as its internal chemical action is concerned. The action of the water and the ammonium chloride in the paste, together with the zinc and carbon electrodes, produces the voltage of the cell. Manganese dioxide is added to reduce polarization when current flows and zinc chloride reduces local action when the cell is not being used.

A cell that is not being used (sitting on the shelf) will gradually deteriorate because of slow internal chemical changes (local action). This deterioration is usually very slow if cells are properly stored. If unused cells are stored in a cool place, their shelf life will be greatly preserved. Therefore, to minimize deterioration, they should be stored in refrigerated spaces.

The blotting paper (paste-coated pulpboard separator) serves two purposes—(1) it keeps the paste from making actual contact with the zinc container and (2) it permits the electrolyte from the paste to filter through to the zinc slowly. The cell is sealed at the top to keep air from entering and drying the electrolyte. Care should be taken to prevent breaking this seal.

Q16. What serves as the cathode of a dry cell?

Q17. Why is a dry cell called a DRY cell?

Q18. What does the term "shelf life" mean?

Mercuric-Oxide Zinc Cell

The mercuric-oxide zinc cell (mercury cell) is a primary cell that was developed during World War II. Two important assets of the mercury cell are its ability to produce current for a long period of time and a long shelf life when compared to the dry cell shown in figure 2-4. The mercury cell also has a very stable output voltage and is a power source that can be made in a small physical size.

With the birth of the space program and the development of small transceivers and miniaturized equipment, a power source of small size was needed. Such equipment requires a small cell which is capable of delivering maximum electrical energy at a constant discharge voltage. The mercury cell, which is one of the smallest cells, meets these requirements.

Present mercury cells are manufactured in three basic types as shown in figure 2-5. The wound-anode type, shown in figure 2-5 view A, has an anode composed of a corrugated zinc strip with a paper absorbent. The zinc is mixed with mercury, and the paper is soaked in the electrolyte which causes it to swell and press against the zinc and make positive contact. This process ensures that the electrolyte makes contact with the anode.

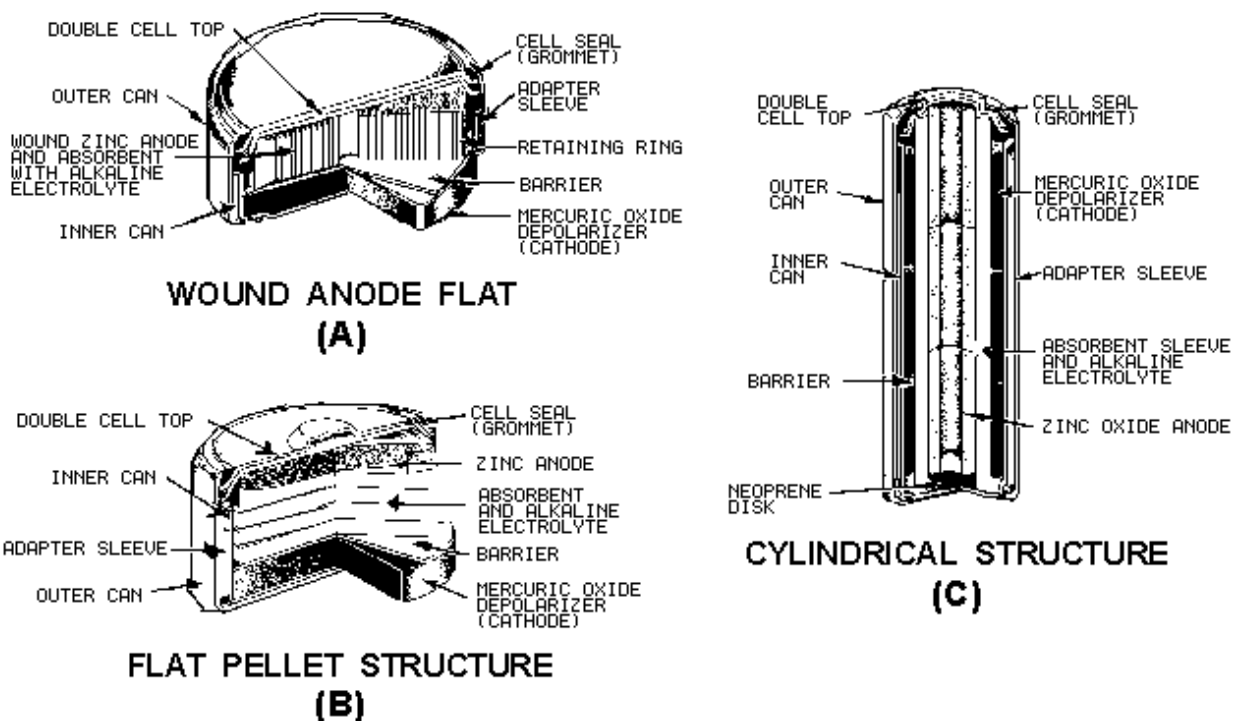

Figure 2-5.—Mercury cells.

In the pressed-powder cells, shown in figure 2-5 views B and C, the zinc powder for the anode is mixed prior to being pressed into shape. The absorbent shown in the figure is paper soaked in the electrolyte. The space between the inner and outer containers provides passage for any gas generated by an improper chemical balance or impurities present within the cell.

If the anode and cathode of a cell are connected together without a load, a **SHORT CIRCUIT** condition exists. Short circuits (shorts) can be very dangerous. They cause excessive heat, pressure, and current flow which may cause serious damage to the cell or be a safety hazard to personnel.

WARNING

Do not short the mercury cell. Shorted mercury cells have exploded with considerable force.

Other Types of Cells

There are many different types of primary cells. Because of such factors as cost, size, ease of replacement, and voltage or current needs, many types of primary cells have been developed. The following is a brief description of some of the primary cells in use today.

The Manganese Dioxide-Alkaline-Zinc Cell is similar to the zinc-carbon cell except for the electrolyte used. This type of cell offers better voltage stability and longer life than the zinc-carbon type. It also has a longer shelf life and can operate over a wide temperature range. The manganese dioxide-alkaline-zinc cell has a voltage of 1.5 volts and is available in a wide range of sizes. This cell is commonly referred to as the alkaline cell.

The Magnesium-Manganese Dioxide Cell uses magnesium as the anode material. This allows a higher output capacity over an extended period of time compared to the zinc-carbon cell. This cell produces a voltage of approximately 2 volts. The disadvantage of this type of cell is the production of hydrogen during its operation.

The Lithium-Organic Cell and the Lithium-Inorganic Cell are recent developments of a new line of high-energy cells. The main advantages of these types of cells are very high power, operation over a wide temperature range, they are lighter than most cells, and have a remarkably long shelf life of up to 20 years.

CAUTION

Lithium cells contain toxic materials under pressure. Do not puncture, recharge, short-circuit, expose to excessively high temperatures, or incinerate. Use these batteries/cells only in approved equipment. Do not throw in trash.

Q19. Why should a mercury cell NOT be shorted?

Q20. What factors should be considered when selecting a primary cell for a power source?

SECONDARY WET CELLS

Secondary cells are sometimes known as wet cells. There are four basic type of wet cells, the lead-acid, nickel-cadmium, silver-zinc, and silver-cadmium.

Lead-Acid Cell

The lead-acid cell is the most widely used secondary cell. The previous explanation of the secondary cell describes exactly the manner in which the lead-acid cell provides electrical power. The discharging and charging action presented in electrochemical action describes the lead-acid cell.

You should recall that the lead-acid cell has an anode of lead peroxide, a cathode of sponge lead, and the electrolyte is sulfuric acid and water.

Nickel-Cadmium Cell

The nickel-cadmium cell (NICAD) is far superior to the lead-acid cell. In comparison to lead-acid cells, these cells generally require less maintenance throughout their service life in regard to the adding of electrolyte or water. The major difference between the nickel-cadmium cell and the lead-acid cell is the material used in the cathode, anode, and electrolyte. In the nickel-cadmium cell the cathode is cadmium hydroxide, the anode is nickel hydroxide, and the electrolyte is potassium hydroxide and water.

The nickel-cadmium and lead-acid cells have capacities that are comparable at normal discharge rates, but at high discharge rates the nickel-cadmium cell can deliver a larger amount of power. In addition the nickel-cadmium cell can:

1. Be charged in a shorter time,
2. Stay idle longer in any state of charge and keep a full charge when stored for a longer period of time, and
3. Be charged and discharged any number of times without any appreciable damage.

Due to their superior capabilities, nickel-cadmium cells are being used extensively in many military applications that require a cell with a high discharge rate. A good example is in the aircraft storage battery.

Silver-Zinc Cells

The silver-zinc cell is used extensively to power emergency equipment. This type of cell is relatively expensive and can be charged and discharged fewer times than other types of cells. When compared to the lead-acid or nickel-cadmium cells, these disadvantages are outweighed by the light weight, small size, and good electrical capacity of the silver-zinc cell.

The silver-zinc cell uses the same electrolyte as the nickel-cadmium cell (potassium hydroxide and water), but the anode and cathode differ from the nickel-cadmium cell. The anode is composed of silver oxide and the cathode is made of zinc.

Silver-Cadmium Cell

The silver-cadmium cell is a fairly recent development for use in storage batteries. The silver-cadmium cell combines some of the better features of the nickel-cadmium and silver-zinc cells. It has more than twice the shelf life of the silver-zinc cell and can be recharged many more times. The disadvantages of the silver-cadmium cell are high cost and low voltage production.

The electrolyte of the silver-cadmium cell is potassium hydroxide and water as in the nickel-cadmium and silver-zinc cells. The anode is silver oxide as in the silver-zinc cell and the cathode is cadmium hydroxide as in the nicad cell. You may notice that different combinations of materials are used to form the electrolyte, cathode, and anode of different cells. These combinations provide the cells with different qualities for many varied applications.

- Q21. What are the four basic types of secondary (wet) cells?*
- Q22. What are the advantages of a nicad cell over a lead-acid cell?*
- Q23. What type of cell is most commonly used for emergency systems?*
- Q24. What three cells use the same electrolyte?*

BATTERIES

A battery is a voltage source that uses chemical action to produce a voltage. In many cases the term battery is applied to a single cell, such as the flashlight battery. In the case of a flashlight that uses a battery of 1.5 volts, the battery is a single cell. The flashlight that is operated by 6 volts uses four cells in a single case and this is a battery composed of more than one cell. There are three ways to combine cells to form a battery.

COMBINING CELLS

In many cases, a battery-powered device may require more electrical energy than one cell can provide. The device may require either a higher voltage or more current, and in some cases both. Under such conditions it is necessary to combine, or interconnect, a sufficient number of cells to meet the higher requirements. Cells connected in **SERIES** provide a higher voltage, while cells connected in **PARALLEL** provide a higher current capacity. To provide adequate power when both voltage and current requirements are greater than the capacity of one cell, a combination **SERIES-PARALLEL** network of cells must be used.

Series-Connected Cells

Assume that a load requires a power supply of 6 volts and a current capacity of 1/8 ampere. Since a single cell normally supplies a voltage of only 1.5 volts, more than one cell is needed. To obtain the higher voltage, the cells are connected in series as shown in figure 2-6.

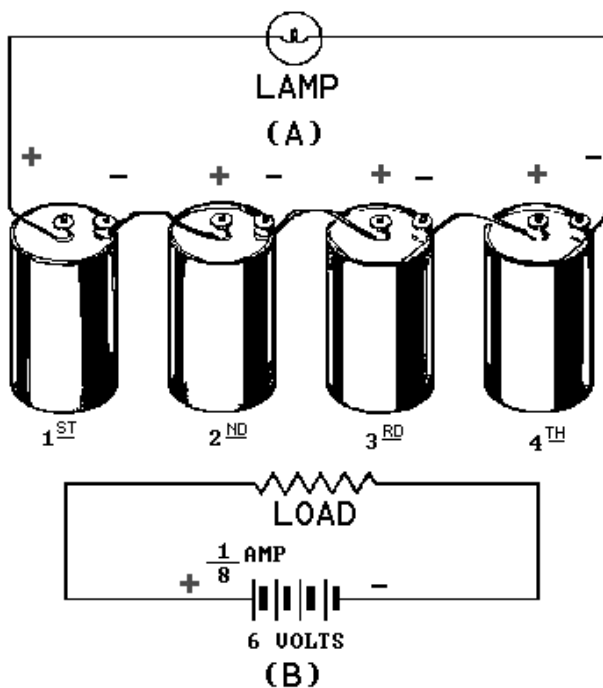

Figure 2-6.—(A) Pictorial view of series-connected cells; (B) Schematic of series connection.

Figure 2-6 view B is a schematic representation of the circuit shown in figure 2-6 view A. The load is shown by the resistance symbol and the battery is indicated by one long and one short line per cell.

In a series hookup, the negative electrode (cathode) of the first cell is connected to the positive electrode (anode) of the second cell, the negative electrode of the second to the positive of the third, etc.

The positive electrode of the first cell and negative electrode of the last cell then serve as the terminals of the battery. In this way, the voltage is 1.5 volts for each cell in the series line. There are four cells, so the output terminal voltage is 1.5×4 , or 6 volts. When connected to the load, $1/8$ ampere flows through the load and each cell of the battery. This is within the capacity of each cell. Therefore, only four series-connected cells are needed to supply this particular load.

CAUTION

When connecting cells in series, connect alternate terminals together (- to +, - to +, etc.) Always have two remaining terminals that are used for connection to the load only. Do not connect the two remaining terminals together as this is a short across the battery and would not only quickly discharge the cells but could cause some types of cells to explode.

Parallel-Connected Cells

In this case, assume an electrical load requires only 1.5 volts, but will require $1/2$ ampere of current. (Assume that a single cell will supply only $1/8$ ampere.) To meet this requirement, the cells are connected in parallel, as shown in figure 2-7 view A and schematically represented in 2-7 view B. In a parallel connection, all positive cell electrodes are connected to one line, and all negative electrodes are connected to the other. No more than one cell is connected between the lines at any one point; so the voltage between the lines is the same as that of one cell, or 1.5 volts. However, each cell may contribute its maximum allowable current of $1/8$ ampere to the line. There are four cells, so the total line current is $1/8 \times 4$, or $1/2$ ampere. In this case four cells in parallel have enough capacity to supply a load requiring $1/2$ ampere at 1.5 volts.

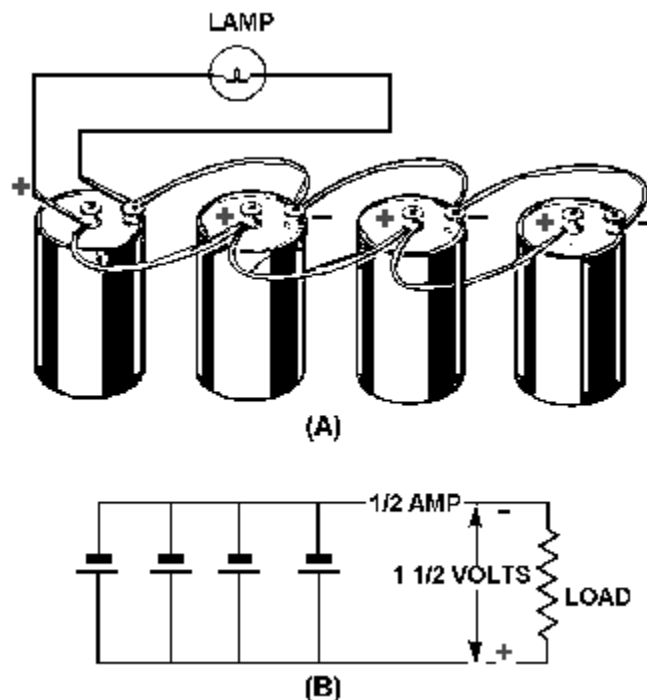

Figure 2-7.—(A) Pictorial view of parallel-connected cells; (B) Schematic of parallel connection.

Series-Parallel-Connected Cells

Figure 2-8 depicts a battery network supplying power to a load requiring both a voltage and a current greater than one cell can provide. To provide the required 4.5 volts, groups of three 1.5-volt cells are connected in series. To provide the required 1/2 ampere of current, four series groups are connected in parallel, each supplying 1/8 ampere of current.

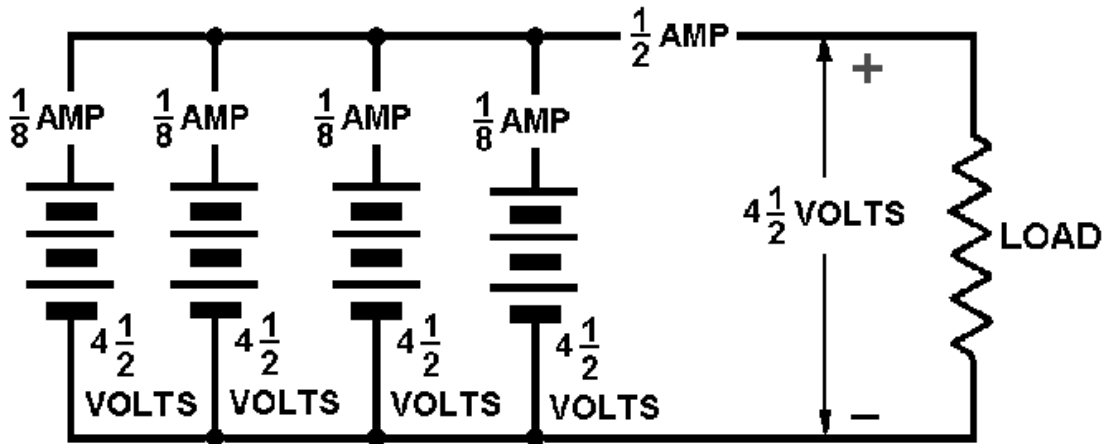

Figure 2-8.—Schematic of series-parallel connected cells.

The connections shown have been used to illustrate the various methods of combining cells to form a battery. Series, parallel, and series-parallel circuits will be covered in detail in the next chapter, "Direct Current."

Some batteries are made from primary cells. When a primary-cell battery is completely discharged, the entire battery must be replaced. Because there is nothing else that can be done to primary cell batteries, the rest of the discussion on batteries will be concerned with batteries made of secondary cells.

Q25. What does the term battery normally refer to?

Q26. What are the three ways of combining cells, and what is each used for?

BATTERY CONSTRUCTION

Secondary cell batteries are constructed using the various secondary cells already described. The lead-acid battery is one of the most common batteries in use today and will be used to explain battery construction. The nickel-cadmium battery is being used with increasing frequency and will also be discussed.

Figure 2-9 shows the makeup of a lead-acid battery. The container houses the separate cells. Most containers are hard rubber, plastic, or some other material that is resistant to the electrolyte and mechanical shock and will withstand extreme temperatures. The container (battery case) is vented through vent plugs to allow the gases that form within the cells to escape. The plates in the battery are the cathodes and anodes that were discussed earlier. In figure 2-10 the negative plate group is the cathode of the individual cells and the positive plate group is the anode. As shown in the figure, the plates are interlaced with a terminal attached to each plate group. The terminals of the individual cells are connected together by link connectors as shown in figure 2-9. The cells are connected in series in the battery and the

positive terminal of one end cell becomes the positive terminal of the battery. The negative terminal of the opposite end cell becomes the negative terminal of the battery.

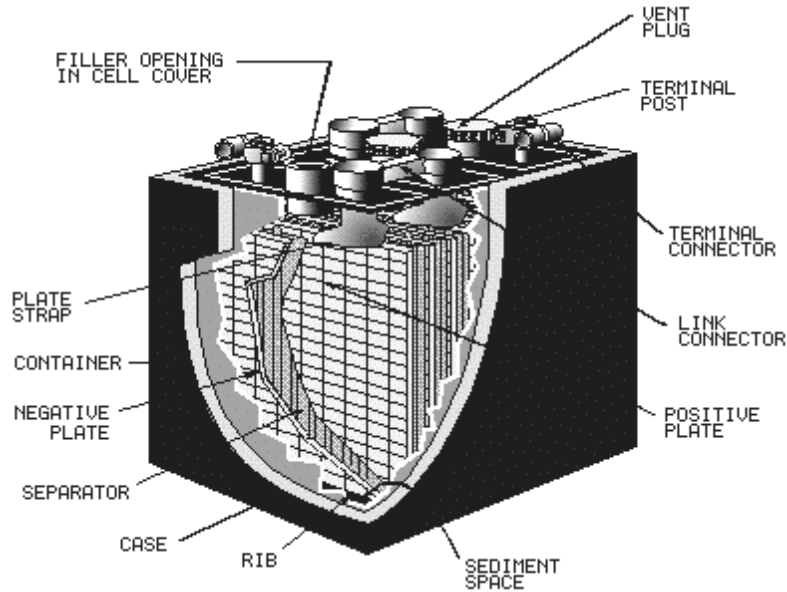

Figure 2-9.—Lead-acid battery construction.

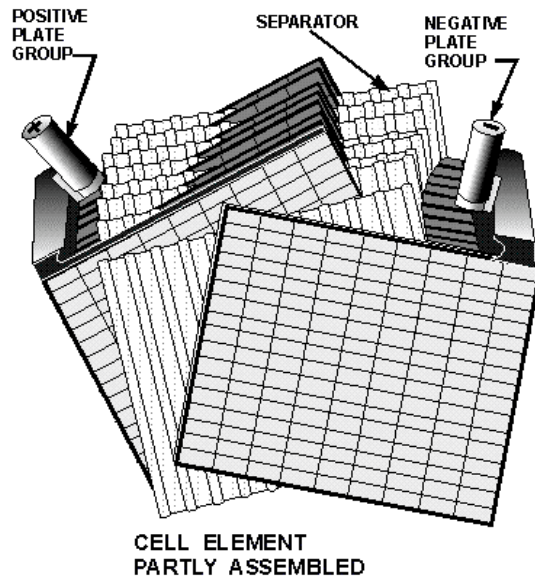

Figure 2-10.—Lead-acid battery plate arrangement.

The terminals of a lead-acid battery are usually identified from one another by their size and markings. The positive terminal, marked (+) is sometimes colored red and is physically larger than the negative terminal, marked (-).

The individual cells of the lead-acid battery are not replaceable, so in the event one cell fails the battery must be replaced.

The nickel-cadmium battery is similar in construction to the lead-acid battery with the exception that it has individual cells which can be replaced. The cell of the nicad battery is shown in figure 2-11.

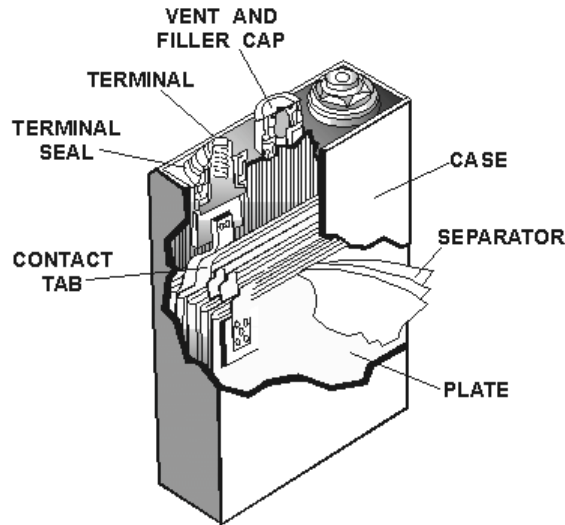

Figure 2-11.—Nickel-cadmium cell.

The construction of secondary cell batteries is so similar, that it is difficult to distinguish the type of battery by simply looking at it. The type of battery must be known to properly check or recharge the battery. Each battery should have a nameplate that gives a description of its type and electrical characteristics.

Q27. Other than the type of cell used, what is the major difference between the construction of the lead-acid and nicad battery?

Q28. How is the type of battery most easily determined?

BATTERY MAINTENANCE

The following information concerns the maintenance of secondary-cell batteries and is of a general nature. You must check the appropriate technical manuals for the specific type of battery prior to performing maintenance on any battery.

Specific Gravity

For a battery to work properly, its electrolyte (water plus active ingredient) must contain a certain amount of active ingredient. Since the active ingredient is dissolved in the water, the *amount* of active ingredient cannot be measured directly. An indirect way to determine whether or not the electrolyte contains the proper amount of active ingredient is to measure the electrolyte's **specific gravity**. Specific gravity is the ratio of the weight of a certain amount of a given substance compared to the weight of the same amount of pure water. The specific gravity of pure water is 1.0. Any substance that floats has a specific gravity less than 1.0. Any substance that sinks has a specific gravity greater than 1.0.

The active ingredient in electrolyte (sulfuric acid, potassium hydroxide, etc.) is heavier than water. Therefore, the electrolyte has a specific gravity greater than 1.0. The acceptable range of specific gravity for a given battery is provided by the battery's manufacturer. To measure a battery's specific gravity, use an instrument called a HYDROMETER.

The Hydrometer

A hydrometer, shown in figure 2-12, is a glass syringe with a float inside it. The float is a hollow glass tube sealed at both ends and weighted at the bottom end, with a scale calibrated in specific gravity marked on its side. To test an electrolyte, draw it into the hydrometer using the suction bulb. Draw enough electrolyte into the hydrometer to make the float rise. Do not draw in so much electrolyte that the float rises into the suction bulb. The float will rise to a point determined by the specific gravity of the electrolyte. If the electrolyte contains a large amount of active ingredient, its specific gravity will be relatively high. The float will rise higher than it would if the electrolyte contained only a small amount of active ingredient.

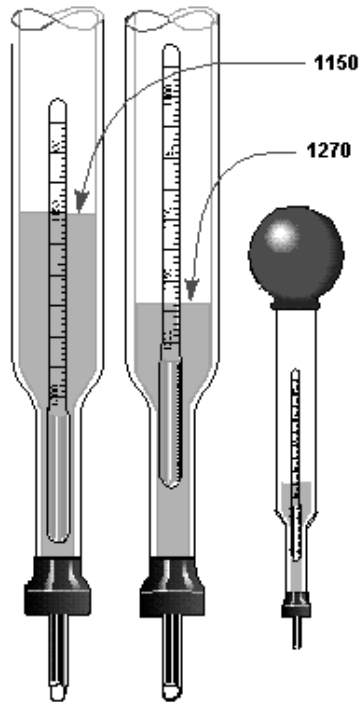

Figure 2-12.—Hydrometer.

To read the hydrometer, hold it in a vertical position and read the scale at the point that surface of the electrolyte touches the float. Refer to the manufacturer's technical manual to determine whether or not the battery's specific gravity is within specifications.

Note: Hydrometers should be flushed with fresh water after each use to prevent inaccurate readings. Storage battery hydrometers must not be used for any other purpose.

Q29. What is the purpose of the hydrometer?

Q30. Which electrolyte has more active ingredient? Electrolyte A, specific gravity 1.015? Electrolyte B, specific gravity 1.125?

Other Maintenance

The routine maintenance of a battery is very simple. Terminals should be checked periodically for cleanliness and good electrical connection. The battery case should be inspected for cleanliness and evidence of damage. The level of electrolyte should be checked and if the electrolyte is low, distilled water should be added to bring the electrolyte to the proper level. Maintenance procedures for batteries are normally determined by higher authority and each command will have detailed procedures for battery care and maintenance.

Safety Precautions With Batteries

All types of batteries should be handled with care:

1. NEVER SHORT THE TERMINALS OF A BATTERY.
2. CARRYING STRAPS SHOULD BE USED WHEN TRANSPORTING BATTERIES.
3. PROTECTIVE CLOTHING, SUCH AS RUBBER APRON, RUBBER GLOVES, AND A FACE SHIELD SHOULD BE WORN WHEN WORKING WITH BATTERIES.
4. NO SMOKING, ELECTRIC SPARKS, OR OPEN FLAMES SHOULD BE PERMITTED NEAR CHARGING BATTERIES.
5. CARE SHOULD BE TAKEN TO PREVENT SPILLING OF THE ELECTROLYTE.

In the event electrolyte is splashed or spilled on a surface, such as the floor or table, it should be diluted with large quantities of water and cleaned up immediately.

If the electrolyte is spilled or splashed on the skin or eyes, IMMEDIATELY flush the skin or eyes with large quantities of fresh water for a minimum of 15 minutes. If the electrolyte is in the eyes, be sure the upper and lower eyelids are pulled out sufficiently to allow the fresh water to flush under the eyelids. The medical department should be notified as soon as possible and informed of the type of electrolyte and the location of the accident.

CAPACITY AND RATING OF BATTERIES

The CAPACITY of a battery is measured in ampere-hours. The ampere-hour capacity is equal to the product of the current in amperes and the time in hours during which the battery will supply this current. The ampere-hour capacity varies inversely with the discharge current. For example, a 400 ampere-hour battery will deliver 400 amperes for 1 hour or 100 amperes for 4 hours.

Storage batteries are RATED according to their rate of discharge and ampere-hour capacity. Most batteries are rated according to a 20-hour rate of discharge. That is, if a fully charged battery is completely discharged during a 20-hour period, it is discharged at the 20-hour rate. Thus, if a battery can deliver 20 amperes continuously for 20 hours, the battery has a rating of 20 amperes \times 20 hours, or 400 ampere-hours. Therefore, the 20-hour rating is equal to the average current that a battery is capable of supplying without interruption for an interval of 20 hours. (Note: Aircraft batteries are rated according to a 1-hour rate of discharge.)

All standard batteries deliver 100 percent of their available capacity if discharged in 20 hours or more, but they will deliver less than their available capacity if discharged at a faster rate. The faster they discharge, the less ampere-hour capacity they have.

The low-voltage limit, as specified by the manufacturer, is the limit beyond which very little useful energy can be obtained from a battery. This low-voltage limit is normally a test used in battery shops to determine the condition of a battery.

Q31. When should safety precautions pertaining to batteries be observed?

Q32. How long should a 200 ampere-hour battery be able to deliver 5 amperes?

BATTERY CHARGING

It should be remembered that adding the active ingredient to the electrolyte of a discharged battery does not recharge the battery. Adding the active ingredient only increases the specific gravity of the electrolyte and does not convert the plates back to active material, and so does not bring the battery back to a charged condition. A charging current must be passed through the battery to recharge it.

Batteries are usually charged in battery shops. Each shop will have specific charging procedures for the types of batteries to be charged. The following discussion will introduce you to the types of battery charges.

The following types of charges may be given to a storage battery, depending upon the condition of the battery:

1. Initial charge
2. Normal charge
3. Equalizing charge
4. Floating charge
5. Fast charge

Initial Charge

When a new battery is shipped dry, the plates are in an uncharged condition. After the electrolyte has been added, it is necessary to charge the battery. This is accomplished by giving the battery a long low-rate initial charge. The charge is given in accordance with the manufacturer's instructions, which are shipped with each battery. If the manufacturer's instructions are not available, reference should be made to the detailed instructions for charging batteries found in current Navy directives.

Normal Charge

A normal charge is a routine charge that is given in accordance with the nameplate data during the ordinary cycle of operation to restore the battery to its charged condition.

Equalizing Charge

An equalizing charge is a special extended normal charge that is given periodically to batteries as part of a maintenance routine. It ensures that all the sulfate is driven from the plates and that all the cells

are restored to a maximum specific gravity. The equalizing charge is continued until the specific gravity of all cells, corrected for temperature, shows no change for a 4-hour period.

Floating Charge

In a floating charge, the charging rate is determined by the battery voltage rather than by a definite current value. The floating charge is used to keep a battery at full charge while the battery is idle or in light duty. It is sometimes referred to as a trickle charge and is accomplished with low current.

Fast Charge

A fast charge is used when a battery must be recharged in the shortest possible time. The charge starts at a much higher rate than is normally used for charging. It should be used only in an emergency, as this type charge may be harmful to the battery.

Charging Rate

Normally, the charging rate of Navy storage batteries is given on the battery nameplate. If the available charging equipment does not have the desired charging rates, the nearest available rates should be used. However, the rate should never be so high that violent gassing (explained later in this text) occurs.

Charging Time

The charge must be continued until the battery is fully charged. Frequent readings of specific gravity should be taken during the charge and compared with the reading taken before the battery was placed on charge.

Gassing

When a battery is being charged, a portion of the energy breaks down the water in the electrolyte. Hydrogen is released at the negative plates and oxygen at the positive plates. These gases bubble up through the electrolyte and collect in the air space at the top of the cell. If violent gassing occurs when the battery is first placed on charge, the charging rate is too high. If the rate is not too high, steady gassing develops as the charging proceeds, indicating that the battery is nearing a fully charged condition.

WARNING

A mixture of hydrogen and air can be dangerously explosive. No smoking, electric sparks, or open flames should be permitted near charging batteries.

Q33. Can a battery be recharged by adding more electrolyte?

Q34. If violent gassing occurs during a battery charge, what action should be taken?

SUMMARY

In this chapter you learned that batteries are widely used as sources of direct-current. You were introduced to electrochemical action and the way it works in a cell, the cell itself, the type and parts of a cell, and how cells are connected together to form batteries. You learned the construction and maintenance of batteries and some of the safety precautions in handling and working with batteries.

Several new terms were introduced in this chapter. The following is a summary of the chapter on batteries.

A CELL is a device that transforms chemical energy into electrical energy. The cell has three parts; the electrodes, the electrolyte, and the container. There are two basic cells: primary and secondary.

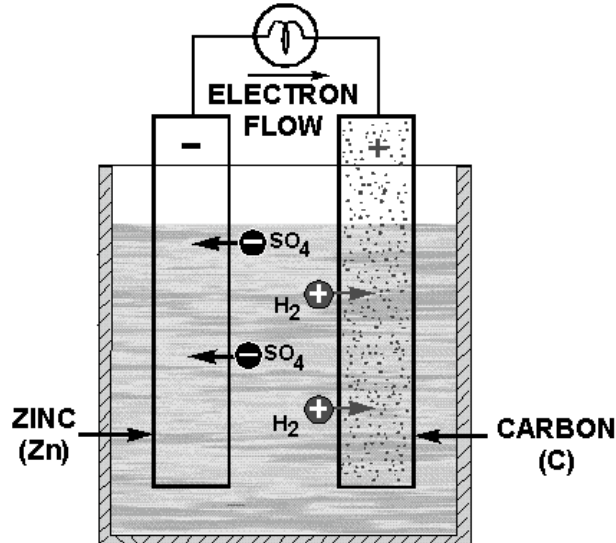

THE ELECTRODES are the current conductors of the cell.

THE ELECTROLYTE is the solution that acts upon the electrodes.

THE CONTAINER holds the electrolyte and provides a means of mounting the electrodes.

THE PRIMARY CELL is a cell in which the chemical action finally destroys one of the electrodes, usually the negative. The primary cell cannot be recharged.

THE SECONDARY CELL is a cell in which the chemical action alters the electrodes and electrolyte. The electrodes and electrolyte can be restored to their original condition by recharging the cell.

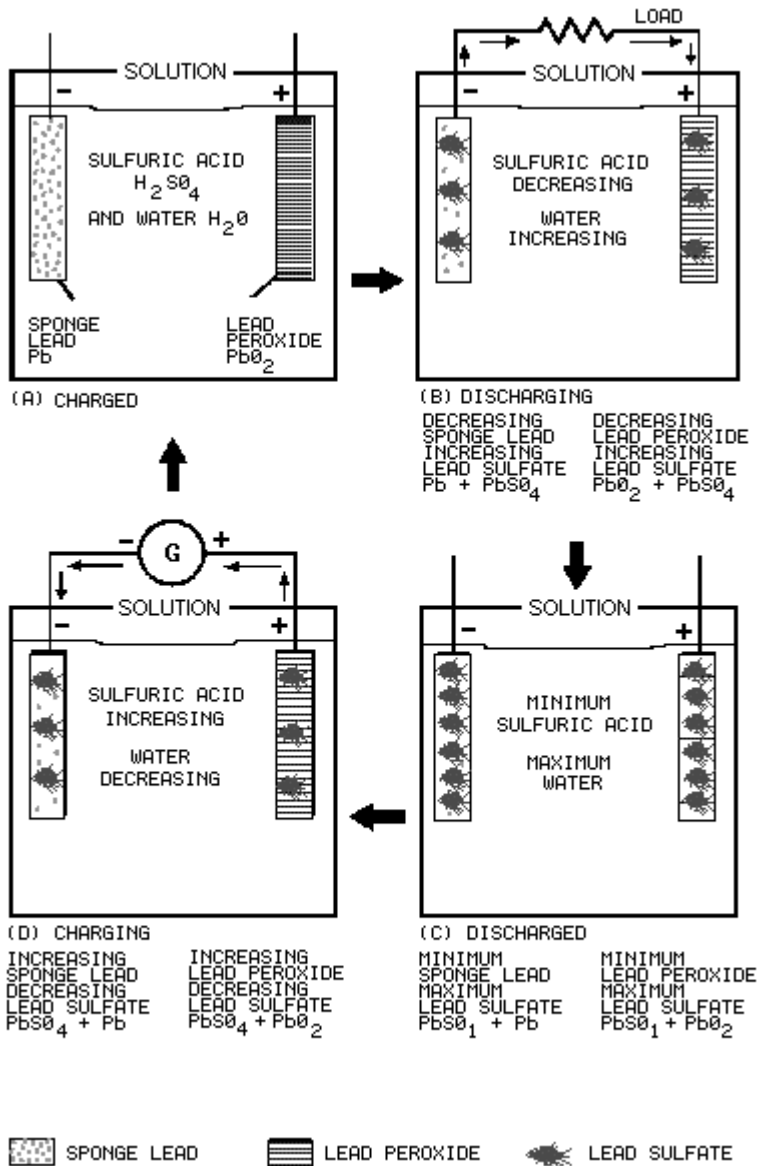

ELECTROCHEMICAL ACTION is the process of converting chemical energy into electrical energy.

THE ANODE is the positive electrode of a cell.

THE CATHODE is the negative electrode of a cell.

PRIMARY CELL CHEMISTRY is the process in which electrons leaving the cathode to the load cause a positive charge which attracts negative ions from the electrolyte. The negative ions combine with the material of the cathode and form a substance such as lead-sulfate. Electrons from the load to the anode create a negative charge which attracts positive ions (hydrogen) from the electrolyte.

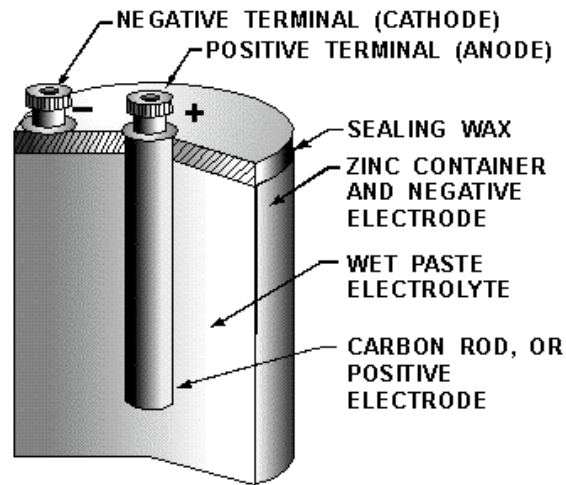

SECONDARY CELL CHEMISTRY is the process in which the electrolyte acts upon and chemically changes both electrodes. This process also depletes the amount of active material in the electrolyte. A charging current applied to the cell reverses the process and restores the cell to its original condition.

POLARIZATION is the effect of hydrogen surrounding the anode of a cell which increases the internal resistance of the cell. Polarization can be prevented by venting the cell, adding a material rich in oxygen, or adding a material that will absorb hydrogen.

LOCAL ACTION is the continuation of current flow within the cell when there is no external load. It is caused by impurities in the electrode and can be prevented by the use of mercury amalgamated with the material of the electrode.

DRY CELL is the type commonly referred to as the "flashlight battery." Since the electrolyte is not in liquid form, but is a paste, the term dry cell is used. In most dry cells the case is the cathode.

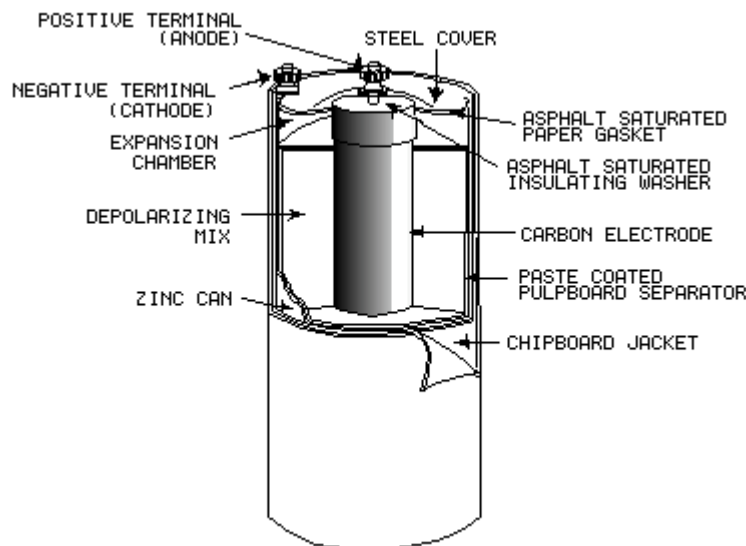

SHELF LIFE is the period the cell may be stored and still be usable.

MERCURY CELLS should never be shorted because of the danger of explosion.

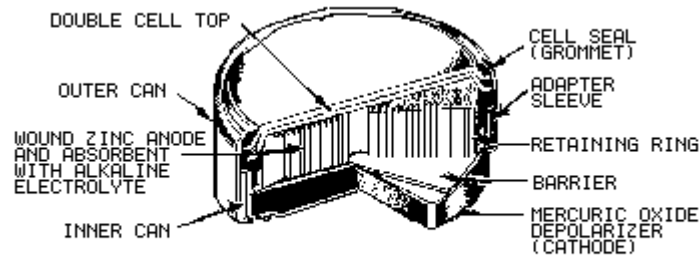

WOUND ANODE FLAT

DRY CELLS are of many types, each having advantages and disadvantages. The type selected for use depends on such factors as cost, size, ease of replacement, and voltage or current needs.

THE LEAD-ACID CELL is the most widely used secondary cell. The lead-acid cell produces electricity by electrochemical action. The anode is lead peroxide, the cathode is sponge lead, and the electrolyte is sulfuric acid and water.

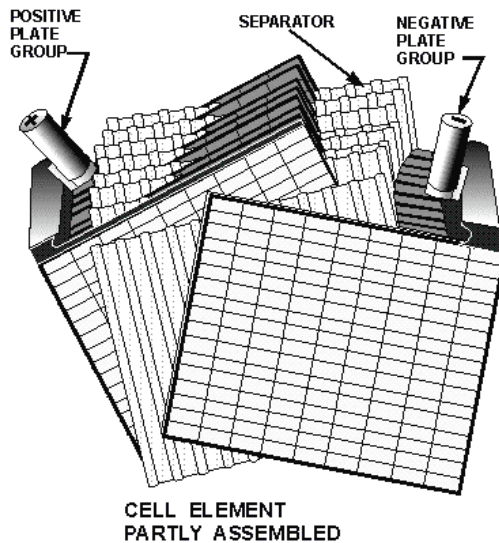

THE NICKEL-CADMIUM CELL, commonly called the NICAD, has the following advantages over the lead-acid cell; charges in a shorter period of time, delivers a larger amount of power, stays idle longer, and can be charged and discharged many times. The anode is nickel hydroxide, the cathode is cadmium hydroxide, and the electrolyte is potassium hydroxide and water.

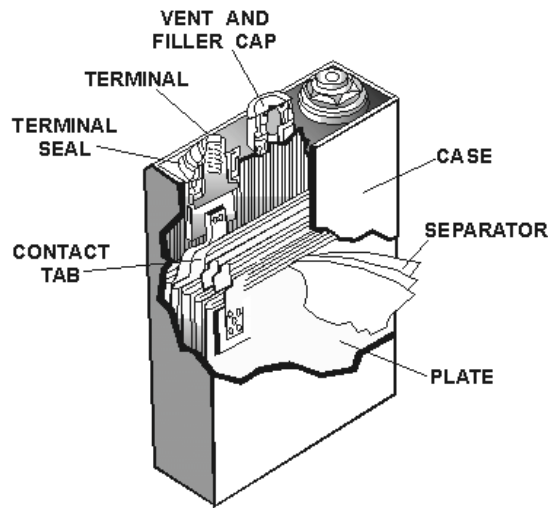

THE SILVER-ZINC CELL is used mostly for emergency equipment. It is light, small, and has a large power capacity for its size. The anode is silver oxide, the cathode is zinc, and the electrolyte is potassium hydroxide and water.

THE SILVER-CADMIUM CELL combines the better features of the nickel-cadmium and silver-zinc cells. The anode is silver-oxide, the cathode is cadmium hydroxide, and the electrolyte is potassium hydroxide.

A BATTERY is a voltage source in a single container made from one or more cells. The cells can be combined in series, parallel, or series-parallel.

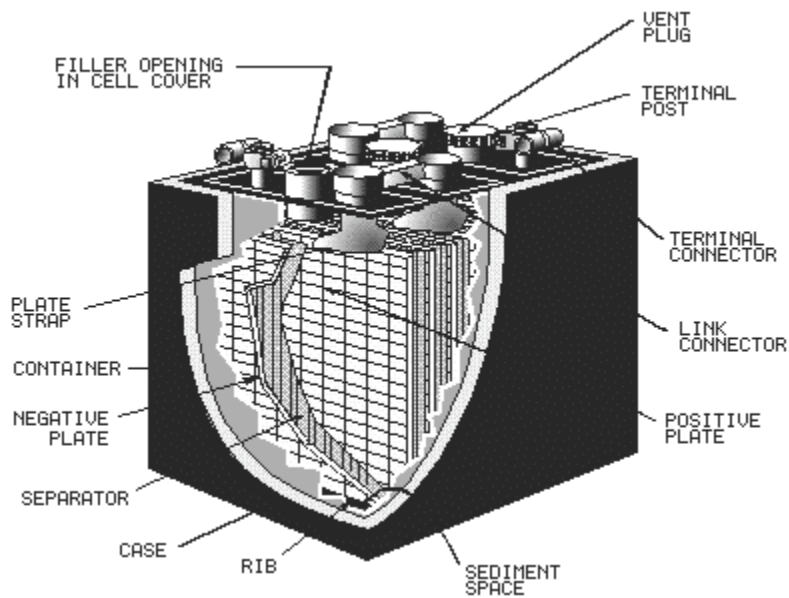

SERIES CONNECTED CELLS provide a higher voltage than a single cell, with no increase in current.

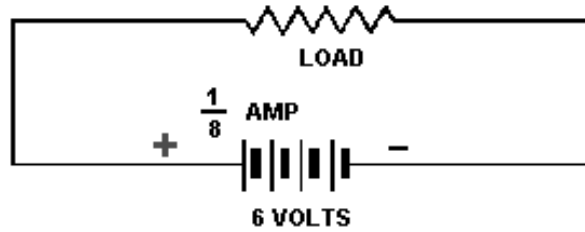

PARALLEL CONNECTED CELLS provide a higher current than a single cell, with no increase in voltage.

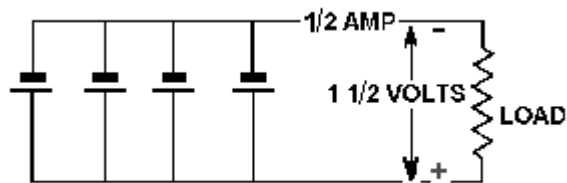

SERIES-PARALLEL CONNECTED CELLS provide a higher voltage and a higher current than a single cell.

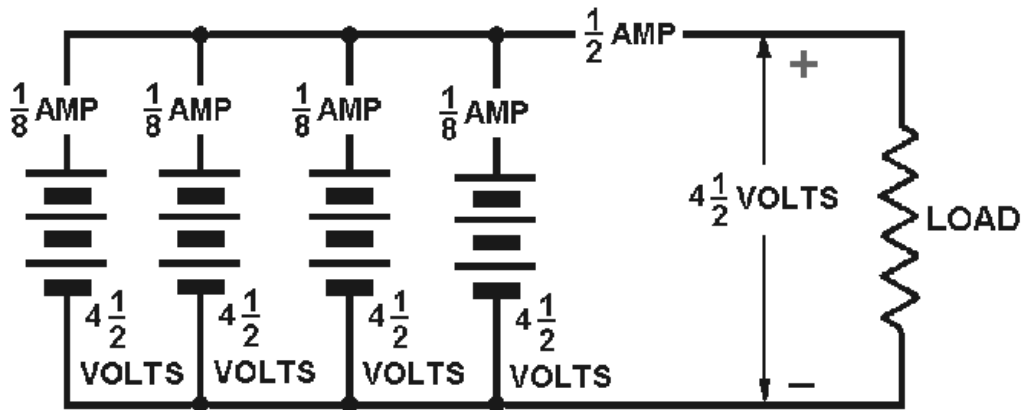

TYPES OF BATTERIES can be determined from nameplate data.

HYDROMETER provides the means to check the specific gravity of the electrolyte.

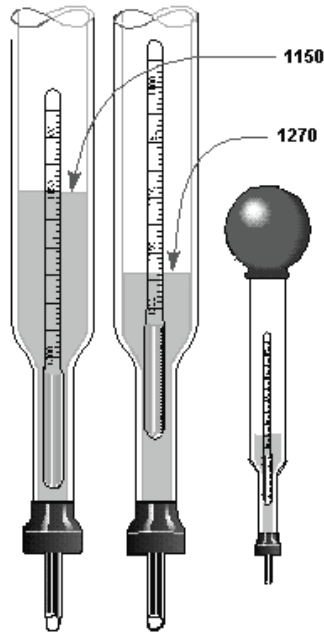

SAFETY PRECAUTIONS should always be followed when working with or around batteries.

CAPACITY is an indication of the current-supplying capability of the battery for a specific period of time; e.g., 400 ampere-hour.

RATING is the capacity of the battery for a specific rate of discharge. In most batteries the rating is given for a 20 hour discharge cycle; e.g., 20 amperes for 20 hours.

BATTERY CHARGE is the process of reversing the current flow through the battery to restore the battery to its original condition. The addition of active ingredient to the electrolyte will not recharge the battery. There are five types of charges:

1. Initial charge
2. Normal charge
3. Equalizing charge
4. Floating charge
5. Fast charge

GASSING is the production of hydrogen gas caused by a portion of the charge current breaking down the water in the electrolyte. Steady gassing is normal during the charging process. Violent gassing indicates that the charge rate is too high.

ANSWERS TO QUESTIONS Q1. THROUGH Q34.

- A1. A cell is a device that converts chemical energy to electrical energy.*
- A2. The electrodes, the electrolyte, and the container.*
- A3. The electrodes are the current conductors of the cell. The electrolyte is the solution that acts upon the electrodes. The container holds the electrolyte and provides a means of mounting the electrodes.*
- A4. Primary and secondary.*
- A5. The secondary cell can be restored to its original condition by an electric current. The primary cell cannot.*
- A6. The process of converting chemical energy into electrical energy.*
- A7. (a) The anode, (b) the cathode.*
- A8. The positive charge caused by electrons leaving the negative electrode attracts the negative ions.*
- A9. By current flow through the load.*
- A10. The chemical action between the negative electrode and the electrolyte.*
- A11. The sulfuric acid is chemically acting upon the anode and cathode which creates a current flow through the load.*
- A12. The charging currents causes the lead sulfate in the anode and cathode to be changed back to lead peroxide, sponge lead, and sulfuric acid.*
- A13. Fully charged.*
- A14. Vent the cell, add a material rich in oxygen, and use a material that will absorb hydrogen.*
- A15. Current flow in a cell with no external load.*
- A16. The zinc container.*
- A17. The electrolyte is not a liquid but is in the form of a paste.*
- A18. The period that a cell can be stored and still be useable.*
- A19. The danger of explosion.*
- A20. Cost, size, ease of replacement, and voltage or current needs.*
- A21. Lead-acid, nickel-cadmium (NICAD), silver-zinc, and silver-cadmium.*
- A22. Can be charged in a shorter time, can deliver a larger amount of power, and stays idle longer.*
- A23. Silver-zinc cell.*
- A24. Silver-cadmium, silver-zinc, and nickel-cadmium.*
- A25. A voltage source in a single container made from one or more cells.*

A26. Series, to increase voltage but not current. Parallel, to increase current but not voltage. Series-Parallel, to increase both current and voltage.

A27. The cells in the nicad battery can be replaced.

A28. By looking at the nameplate data.

A29. To measure the amount of active ingredient in the electrolyte.

A30. Electrolyte B. It is heavier per unit volume.

A31. At all times.

A32. Forty hours.

A33. No, a current must be passed through the battery.

A34. Reduce the charging rate.

